

DEVELON

Mini Excavators

DX17Z



Maximum power 14,7 hp
Operating weight 1,7 t



THE MOST COMPACT, AND THE MOST COMFORTABLE!

The sophisticated ISO-certified TOPS/ROPS/FOPS canopy – together with excellent visibility and stability – provide optimal operator comfort and safety. Comfortably seated, you have easy access to several storage compartments and a clear all-round view of the worksite. Noise and vibration levels are minimised.

COMPACT TO WORK IN CONFINED AREA, WITH THE COMFORT OF A HEAVY EXCAVATOR

Proportional auxiliary flow means that the excavator's power is matched by smooth, confident manoeuvres. Using sensitive joysticks and clear controls positioned for convenient access, you work safely and confidently with minimum effort. Even the switches have been ergonomically placed and positioned according to the frequency with which they are used. The highest standards of efficiency are at your fingertips.



OPERATOR COMFORT

The DX17Z provides an uncompromised operator environment – which, together with excellent visibility, provides unmatched operator comfort and safety.

- This machine is built around the operator – providing optimal ergonomics for operators of all sizes.
- Access to the seat is convenient thanks to the large entry and the console that rises completely out of the way. In addition, when not in use, the foldable pedals increase room for the feet.

SUPERIOR INTERIOR ITEMS GUARANTEE EXTRAORDINARY EXPERIENCE

- Large and spacious canopy
- Convenient space for the feet with flat floor for easy cleaning
- Easy entry and exit
- Ergonomic pedals and access to all controls
- Cup holders



ZERO HOUSE SWING

The Zero House Swing (ZHS) concept is a step above the Zero Tail Swing (ZTS) functionality as it fully protects the front upper structure corners within the swing circle.

- ZHS functionality provides 320° of free rotation while working close to any object.
- With our DX17Z, you get ZHS without sacrificing operator comfort or performance.



MAXIMUM STABILITY AND VERSATILITY WITH POWERFUL HYDRAULICS

ADAPTABLE & SMOOTH

The DX17Z open center hydraulic system with variable displacement pumps uses the engine's power more effectively, maximising pump output and offering more comfort, smoothness and accuracy.

- Fast cycle times, together with class-leading breakout forces, ensure maximum productivity
- Boom and arm cylinder cushioning increases overall smoothness
- Retractable undercarriage lets you enter buildings through the door. Fully extended, it brings you optimum stability
- Variety of attachments provide maximum versatility

VERSATILITY WITH POWERFUL HYDRAULICS

This machine makes the best possible use of the engine power. Fast cycle times, combined with smooth control of class-leading breakout forces, provide maximum productivity. Boom and arm cylinder cushioning – unique in their class – enhance overall smoothness of the workgroup.

1. The DX17Z incorporates the architecture of the 2-ton class hydraulic system with a combination of variable piston pumps and gear pump.
2. With optimized stability and lifting capacity, the DX17Z offers you the highest versatility in operating a wide range of attachments.



MAXIMUM STABILITY

Stability is essential for making maximum use of the digging forces and lifting capacities. Optimum stability is achieved by fully expanding the retractable undercarriage and using the long dozer blade. The following features make the stability of the Develon DX17Z very competitive with all other zero tail swing machines on the market:

1. Retractable undercarriage: When fully retracted, the undercarriage allows the excavator to go through narrow spaces; and fully expanded provides optimum stability for the excavator, especially when working over the side. Expansion and retraction are simple and easy via an electric switch on the control panel.
2. Long dozer blade: On top of its dustpan functionality, the (optional) long dozer blade also significantly improves front stability, enabling the operator to fully use the breakout forces the machine delivers.

SUPERIOR LIFTING CAPACITY & EASY TRANSPORTATION

LIFT MORE, LIFT HIGHER

The superior dumping height makes loading trucks easy, while the reach at ground level means you don't need to reposition as often when digging. With enhanced stability and lifting capacity, combined with best-in-class proportional auxiliary flow, the DX17Z offers you the highest versatility in operating a wide range of attachments.

SUPERIOR LIFTING CAPACITY

1. The superior dumping height makes loading trucks easy, while the reach at ground level means you don't need to reposition as often when digging.
2. Picking up and placing heavy items is quite easy. The DX17Z's stability is equal to the best-in-class zero tail swing machines on the market. In addition, this machine comes with an optional certified 'object handling device', which consists of: boom load holding valve, arm load holding valve, hooking device and overload warning device.



EASY TRANSPORTATION

The new DX17Z Develon model with transport weight less than 1.65 tons is towable on trailers for 2200 kg of total weight.

- According to the "European Transport Regulations", the maximum towable weight for a BE license is 3500 kg.
- And transportability is made even easier with the new integrated upper-structure tie-down points.



DEPENDABLE PERFORMANCE FOR LOW LIFETIME COST

The reinforced chassis provides strength, while the optimised boom shape ensures uniform load distribution for greater durability. Top quality materials, the most advanced computer-aided design, and endurance testing under the most demanding conditions ensure your excavator keeps on performing. The DX17Z is designed for low maintenance with longer intervals – resulting in more machine availability on-site. Meanwhile, skilled Develon-trained technicians are available to provide extra support when needed.

MORE DURABLE AND EASY MAINTENANCE

RELIABILITY IS THE KEY

Using highly durable materials makes the DX17Z model hard-wearing robust and easy to repair. The design features are tested under extreme conditions – the heavy steel gauge covers and tailgate ensure class leading durability and peace of mind while working.

- Reliability added to every feature
- Rear tailgate protected by casted counterweight
- Openable or bolted on covers
- Two-piece blade cylinder hoses to simplify replacement in case of damage
- Wrenchless hydraulic hose technology helps prevent leakage
- Proven boom and dipper-stick design
- Protected top-mounted boom cylinder
- Oversized cylinders for long lifetime
- New paint and surface treatment process for durability and residual value
- Reinforced expandable undercarriage to maximize rigidity



EASY ACCESS FOR MAINTENANCE

Right from the start, we paid particular attention to easy service access: these units have a single access point for the daily maintenance of all the main components, for checking the fuel gauge and refueling through the lockable cap.



TECHNICAL SPECIFICATIONS

ENGINE

Model

Yanmar / 3TNV74F-SPBC (EU Stage V)

No. of cylinders

3

Piston displacement

0.993 l

Max. net power at 2400 rpm

ISO 14396 11,0 kW (14.7 hp)

Max. net torque at 1800 rpm

SAE J1995 5,11 kgf/m (50.2 Nm)

Bore × stroke

74 mm × 77 mm

HYDRAULIC SYSTEM

Pump type

Dual outlet variable displacement piston pump with gear pumps

Pump capacity

2 × 15 l/min

Gear pump capacity

11.3 l/min

Auxiliary flow

30 l/min

Auxiliary relief

180 bar

PERFORMANCE

Bucket digging force (ISO 6015)

16177 N

Arm digging force (ISO 6015)

9108 N

Drawbar pull

19302 N

Travel speed fast / slow

4.0 / 2,48 km/h

Gradeability

30°

WEIGHTS

Operating weight with ROPS canopy

ISO 6016 1749 kg

Transport weight (bucket and operator excluded)

1632 kg

Ground pressure with rubber tracks

30.06 kPa (4360 psi)

SWING MECHANISM

Swing speed

10.1 rpm

Boom swing angle L/R

80° / 60°

Swing drive

Orbit motor

ENVIRONMENTAL

A-weighted emission sound pressure level at the operator's position

LpAd (2000/14/EC) 80 dB(A)

A-weighted sound power level

LwAd (2000/14/EC) 93 dB(A)

Whole body vibration (ISO 2631-1)

0.14 ms⁻²

Hand-arm vibration (ISO 5349-1)

0.49 ms⁻²

FLUID CAPACITIES

Fuel tank	19 l
Hydraulic system	14.3 l
Cooling system	19.0 l
Engine oil plus oil filter	3.3 l

DIMENSIONS AND WORKING RANGE

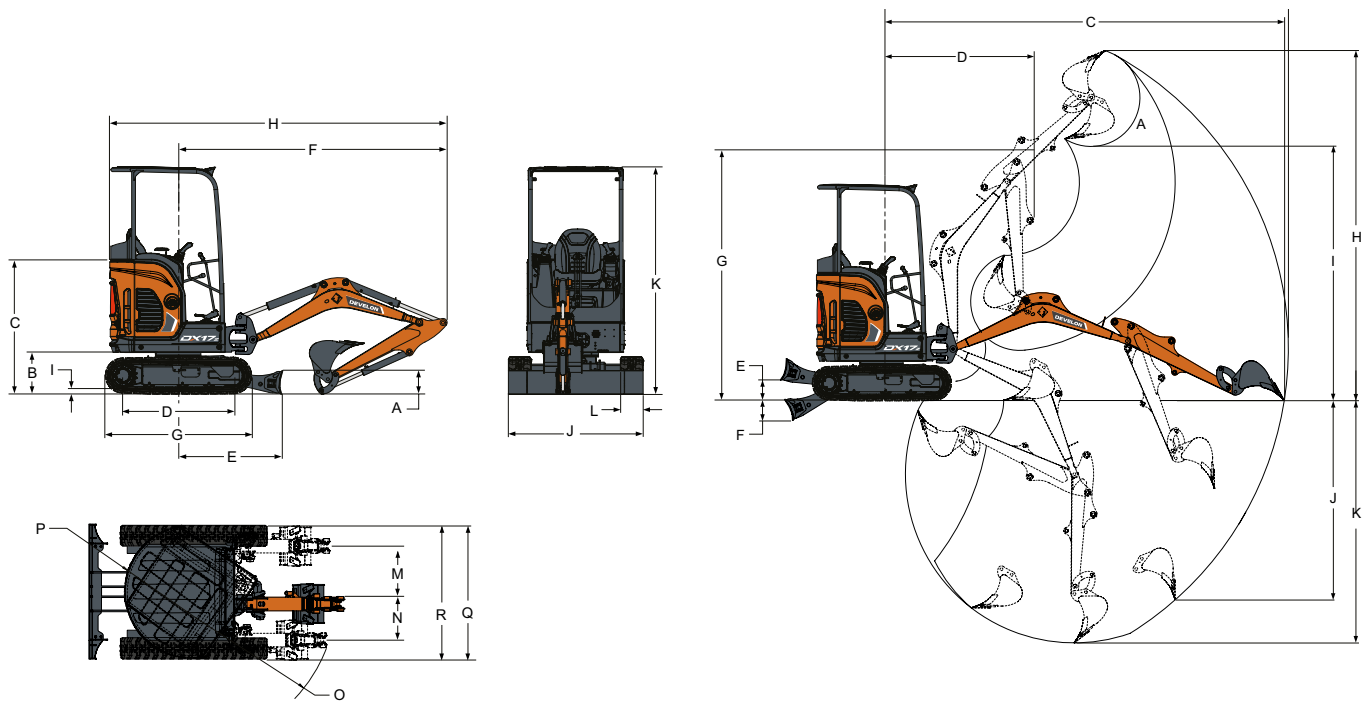

DIMENSIONS

A	Blade height	235 mm
B	Ground clearance	419 mm
C	Engine cover height	1138 mm
D	Length of track on ground	1114 mm
E	Machine centre line to blade, std / long dozer blade	1045 / 1252 mm
F	Min. radius in travel position	2715 mm
G	Overall track length	1476 mm
H	Shipping length	3450 mm
I	Track lug height	25 mm
J	Blade width (retracted)	1360 (980) mm
K	Overall height	2297 mm
L	Track width	230 mm
M	LH boom offset	450 mm
N	RH boom offset	638 mm
O	Min. turning radius	1190 mm
P	Swing clearance, rear	690 mm
Q	Working width at max. RH rotation	1532 mm
R	Working width at max. LH rotation	1370 mm

WORKING RANGE

A	Bucket pivot angle	196°
B	Max. reach	3971 mm
C	Max. reach at ground level	3923 mm
D	Min. swing radius	1560 mm
E	Max. blade height / long dozer blade	220 / 300 mm
F	Max. blade depth / long dozer blade	204 / 254 mm
G	Max. height at min. swing radius	2406 mm
H	Max. digging height	3378 mm
I	Max. dump height	2369 mm
J	Max. vertical wall depth	1810 mm
K	Max. digging depth	2249 mm

LIFTING CAPACITIES

LIFTING CAPACITIES • OVER BLADE • BLADE DOWN

Lift point height (mm)	Maximum radius (mm)	Lift at max. radius (kg)	Lift at 2000 mm radius (kg)	Lift at 3000 mm radius (kg)
2000	3000	344*	-	-
1000	3380	337*	438*	369*
Ground	3350	320*	742*	398*
-1000	2940	306*	609*	-

LIFTING CAPACITIES • OVER BLADE • BLADE UP

Lift point height (mm)	Maximum radius (mm)	Lift at max. radius (kg)	Lift at 2000 mm radius (kg)	Lift at 3000 mm radius (kg)
2000	3000	233	-	-
1000	3380	190	425	229
Ground	3350	182	380	214
-1000	2940	215	363	-

LIFTING CAPACITIES • OVER SIDE • BLADE UP

Lift point height (mm)	Maximum radius (mm)	Lift at max. radius (kg)	Lift at 2000 mm radius (kg)	Lift at 3000 mm radius (kg)
2000	3000	263	-	-
1000	3380	218	438*	264
Ground	3350	210	431	251
-1000	2940	249	425	-

1. Lifting capacities are in compliance with ISO 10567:2007(E).

2. The load point is at the end of the arm.

3. * Rated hydraulic lift capacity.

4. The nominal loads shown do not exceed 75% of tipping loads or 87% of hydraulic lifting capacity.

5. For lifting capacity with bucket, simply subtract the actual weight of the bucket from the values.

6. The configurations indicated do not necessarily reflect the standard equipment of the machine.

STANDARD AND OPTIONAL EQUIPMENT

● Standard ○ Optional

- TOPS/ROPS/FOPS canopy
- ZHS upper-structure concept
- Extendable undercarriage
- Track expansion switch
- Lights front canopy
- Two-speed travel
- 980 mm dozer blade with two blade extensions (1360 mm extended)
- 1st auxiliary line (double acting) with auxiliary caps on Arm
- Hydraulic joystick control
- Stationary seat
- Control console locks
- Foldable & ergonomic pedals
- Engine speed control lever
- Upper-structure four-point tie down
- Advanced service diagnostics
- Engine with overheat automatic shutdown
- Full fuel warning alarm
- Hydraulic and travel control lockouts
- Battery switch off
- Spark arrester muffler
- Boom light metal protection
- Storage compartment
- Cup holders
- Demolition Kit consists of an hydraulic oil cooler for breaker application
- Long dozer blade
- Develon Hydraulic Breaker HB03H, 700-1200 bpm, 120 dB



OPTIONAL ATTACHMENTS

NEED A BREAK?



Available on 1 to 10 tons Excavators

OPTIMIZED PERFORMANCE

HB series are optimized for Develon Excavators, fully certified by Develon engineering.

PERFORMANCE

Develon HB breakers offer powerful performance and top notch productivity, whether you are demolishing concrete or breaking rocks.

WARRANTY

Avoid compatibility and warranty coverage arguments from using non-approved breaker. Develon offers standard warranty up to 2 years.

TOTAL COST OF OWNERSHIP

Even with 2-year warranty, HB-series are offered at reasonable price, providing customer benefits in total cost of ownership.

BUCKETS SETS

Whatever the width, tackle any digging operation with our buckets sets.

Available on 1 to 10 tons Excavators

Each set contains:

- 1 pin-on quick coupler
- 3 digging buckets with teeth
- 1 grading bucket

SIDE CUTTERS & BOTTOM WEAR STRAPS

The digging buckets are equipped with thick and chamfered side cutters, and bottom wear straps covering 90% of the bottom of the bucket.

INCREASED STIFFNESS

The grading bucket is equipped with one or more web plates to increase the stiffness of the bucket.



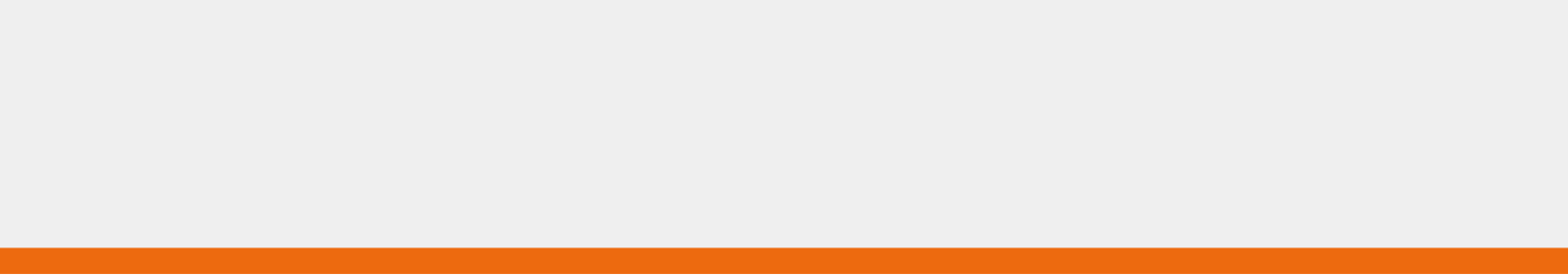

Lined writing area with horizontal rules.





Powered by Innovation

DISCOVER MORE:
DX17Z

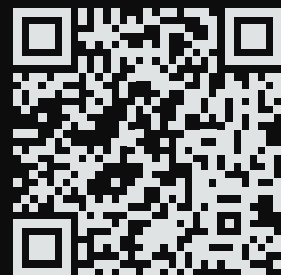

DEVELON

HD Hyundai Infracore Europe s.r.o.
IBC - Pobřežní 620/3, 186 00 Praha 8-Karlín
Czech Republic

©2023 DEVELON D4600113-EN (08-23)

Certain specification(s) are based on engineering calculations and are not actual measurements. Specification(s) are provided for comparison purposes only and are subject to change without notice. Specification(s) for your individual Develon equipment will vary based on normal variations in design, manufacturing, operating conditions, and other factors. Pictures of Develon units may show other than standard equipment.